

## Handbook for International Students



## Contents

Things to do before travelling to Germany .....	3
Residence permit: for students who are not from an EU member country	4
Resident registration for all students .....	4
Health insurance.....	5
Opening a bank account .....	6
Accommodation and lifestyle.....	6
Accommodation – Student residences .....	7
Private student residences .....	7
Advice/Tips & Tricks .....	8
GEZ Licence fee for citizens.....	8
10 Facts you need to know about living in Germany .....	10
Map Deggendorf .....	11
Important semester dates.....	12
Important telephone numbers .....	12
Contact and advice .....	12
Library .....	13
Centre for studies .....	13
Career Service.....	13
International Office .....	14
Language and electives centre.....	14
Copy Shop .....	14
Campus Canteen and Café .....	14
Sports .....	15
Student ID .....	15
First steps in the IT .....	16

Dear students,

Welcome to Deggendorf! We are glad to see that you have decided to study in Germany in our charming town with its scenic landscape. This brochure provides information about studying at the Deggendorf Institute of Technology. Please read it carefully! It offers lots of important information for you.

## ▶ Things to do before travelling to Germany

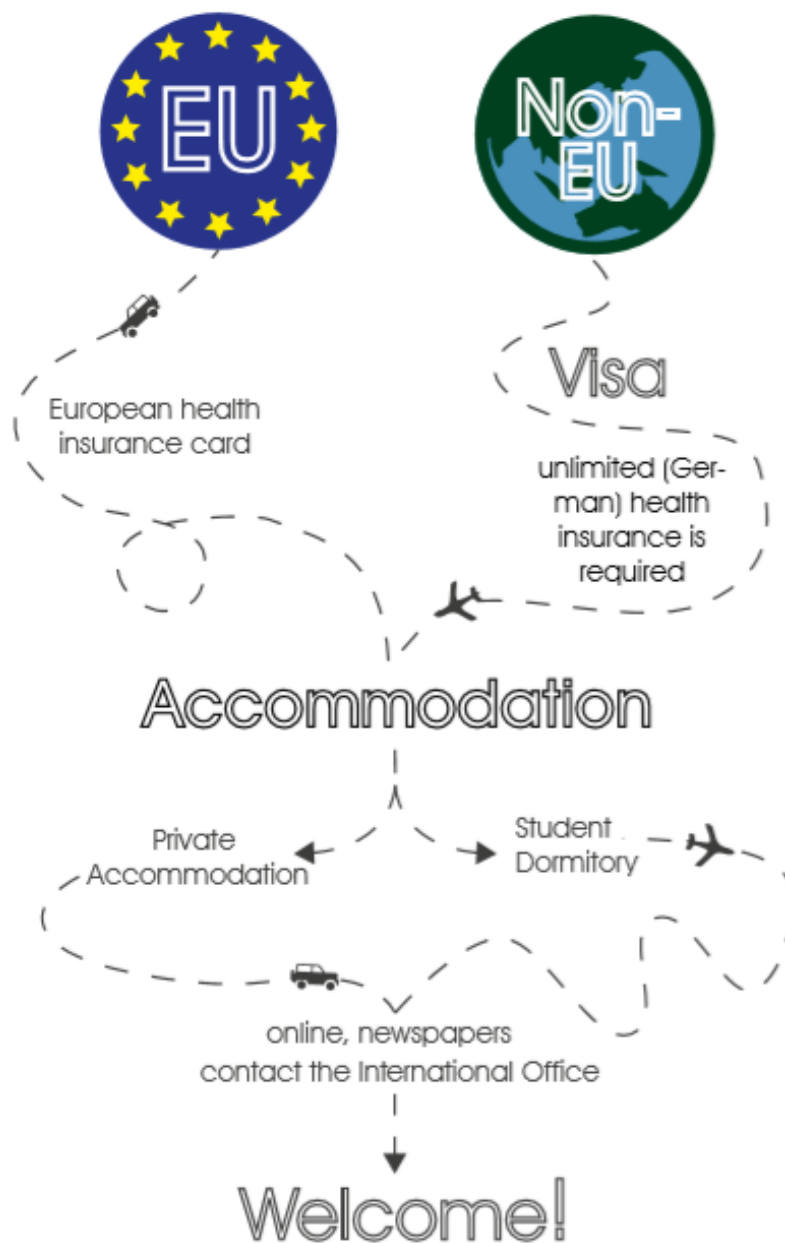

## ▶ Residence permit: for students who are not from an EU member country

Students who are not from an EU member country need to apply for a residence permit ("Aufenthaltsgenehmigung"). To obtain it, you must go to the local Immigration Office ("Ausländeramt"). It is situated in the District Office ("Landratsamt").

You are required to bring along the following documents:

- Passport or ID card
- 3 biometrical photographs
- Enrolment certificate („Immatrikulationsbescheinigung“)
- Proof of health insurance
- Proof of financial support or enough funds
- Copy of birth certificate

Certain nationalities need to open a blocked bank account to be able to apply for a student visa. Please contact the German Embassy in your home country.

### **Contact Deggendorf:**

Landratsamt Deggendorf  
 Ausländeramt or Foreigners' Office  
 Herrenstraße 18  
 94469 Deggendorf  
 Tel: +49 (0)991 3100-227  
[auslaenderwesen@lradeq.bayern.de](mailto:auslaenderwesen@lradeq.bayern.de)

## ▶ Resident registration for all students

Germany has compulsory registration for everybody who lives here. If you stay longer than three months, registration should be done within the first two weeks after moving to Germany.

To registry you will need the following:

- Passport
- Filled in „Wohnungsbestätigung“ (from your landlord)

The registration office is located in the town hall (Rathaus). If you live in another village/city you have to go to this town hall.

## **Rathaus Deggendorf**

Bürgeramt

Franz-Josef-Strauss-Straße 3

94469 Deggendorf

Telephone +49 (0)991 2960-333

## **Health insurance**

Under German law, everyone studying at a state-recognised college or university is required to take out personal health insurance. Therefore, you will need to submit an insurance certificate when you enroll at college or university. If you do not have private insurance that fulfils the requirements mentioned below, it is recommended that you apply for a German health insurance card.

Please bring with you:

- Enrollment certificate („Immatrikulationsbescheinigung“)
- Passport
- Student ID card
- German bank account number

For EU citizens:

If you are from an EU-country and are already covered by public health insurance in your home country, you are entitled to use public medical care in Germany. Your health insurance will cover all occurring costs for medical treatment.

If you are not a citizen of the European Union:

- You need to take out German health insurance, which costs around €70 monthly.
- If you have health insurance in your home country, you have to bring a certificate from your company, which shows that your health insurance will fulfill the requirements stated in §7 Abs.2 of the „Freizügigkeitsverordnung/EG“.

**If you don't have German health insurance, you will need confirmation from a German insurance company that you are exempt from taking out public health insurance. You need to show this confirmation at the Centre for Studies**

## Opening a bank account

Official payments are made through bank transfers, e.g. rent to your landlord. Therefore it is useful to open a bank account which usually take about 30 minutes.

Please bring the following items:

- Passporto r ID-card including visa
- Proof of enrollment (if you don't have it yet, you can submit it later)

It is important to mention that you are a student, because opening an account and bank transactions are free of charge for students. If you do not let the bank know about your student status, there will be a fee. The bank will automatically give you an info card with your account number, bank code, phone number and contact person. You also obtain a cash card, which you can use in Germany and abroad.

## Accomodation and lifestyle

Deggendorf Institute of Technology is located in a touristic town with a population of 40,000 on the banks of the River Danube. It's a charming location at the foot of the Bavarian mountains, just north of Munich in Southern Germany and close to the Austrian border and the Alps.

Our students enjoy vibrant social lives as Deggendorf has plenty to offer! The town has a great variety of restaurants, cafes and pubs to offer, plus many cultural festivals and events. It has an excellent network of bike trails, leisure cruise ships on the river and a surrounding hilly landscape that provides a stunning natural backdrop to enjoy the countless recreational activities on offer.

The campus is within easy walking distance of town centre, student accommodation and all local amenities.

Additionally, Deggendorf has excellent public transport links including Munich international airport only one hour away, making travelling quick, efficient and enjoyable.

Here are some of the local recreational activities in the vicinity:

- A modern rowing club on the River Danube just 50 yards from campus
- Skiing slopes 20 minutes away
- Mountain biking, hiking and paved inline skating trails are all around
- A fantastic indoor and outdoor recreational swimming oasis

- An indoor ice rink for ice skating and ice hockey
- Rock climbing and paragliding centres near by
- The famous FC Bayern Munich football stadium is just one hours drive away
- Plus, all students can participate in the university clubs which offer a vast variety of sports and social activities.

## Accomodation – Student residences

The majority of DIT's international students lives in the ten student apartment blocks, which are within easy walking distance of campus and all other amenities in town. Most of these flats are in so-called 'student parks' which are attractive low level apartment blocks consisting of small, modern and newly built furnished and self-contained flats for single occupation, although other options are available. Most student parks have a communal lounge, laundry room, wifi, parking spaces and bike lock-up.

All prices are received by the dormitory management.

Please be aware that the student residences normally request 6 months rent in advance (in addition to the rental deposit). Contact: [welcome@th-deg.de](mailto:welcome@th-deg.de)

## Private student residences

To find a private accommodation please check these websites:

- [www.th-deg.de/wb](http://www.th-deg.de/wb)
- [www.stwno.de](http://www.stwno.de)
- [www.wg-gesucht.de](http://www.wg-gesucht.de)

**Please pay attention to the following points which are important for you:**

- Deposit - you are always asked to pay a deposit sum between €300 and €600
- Private accommodation is available in different parts of the town.
- You have to remain there for the whole period of your stay once you have accepted it.
- Telephone and Internet access are not always available.
- Rental prices range from € 230,- to € 350,- plus utility costs of € 35,- to € 80,- per month.
- All rooms/apartments are self catering.
- You must CANCEL YOUR FLAT CONTRACT 3 MONTHS BEFORE LEAVING!

## Advice/Tips & Tricks

### **Energy and waste**

Try to save energy and separate waste:

- **Waste separation:**  
Waste paper and glass belong in the waste containers. Emptied and clean packaging belong in the yellow bag (only in some cities). Raw vegetable peelings and coffee grounds belong in the bio-bin if available. All the rest belongs in the residual waste.
- **Deposit system:**  
When you buy a bottle in any store or a can of any beverage, there is a 7 - 25 cent deposit on it. You can return the empty bottle / can to any food store and you will get the deposit back:

### **How to air your room correctly:**

Switch off the heaters while airing the room. Air two to three times a day with the window wide open, no permanent airing with the window on tilt (provokes mould).

### **Utilities ("Nebenkosten"):**

Higher costs can occur through wasting energy and water which then have to be put on top of the rent (you get a bill in the beginning of the new calendar year with the additional costs for electricity and water). You would have to pay for it after your move-out (or they keep a part of your deposit instead).

### **Repairs:**

If something is broken or damaged, report it to the landlord immediately. Repairs that do not have to be carried out immediately will be attended to by the facility manager as soon as possible after having received the damage report. Emergencies (e.g. flooding) will be attended to by the on-duty service, if the facility manager is off-duty.

## GEZ Licence fee for citizens

We have long been able to watch television programmes on a tablet and listen to radio on a smart phone. Technical equipment offers an increasing number of functions and changes in the way we use media content.

Device-independent licence fees are modern and open to technological progress.

For €17.50 per month the licence fee covers all public service broadcasting programmes over all means of distributions. It also ensures that there will be a varied and freely available programme for all citizens in the future.



Find more information under:

[www.rundfunkbeitrag.de/e175/e198/Informationsflyer\\_Buergerinnen\\_und\\_Buerger\\_englisch.pdf](http://www.rundfunkbeitrag.de/e175/e198/Informationsflyer_Buergerinnen_und_Buerger_englisch.pdf)

## 10 Facts you need to know about living in Germany

- Stop! Think before you dial 112. It isn't appropriate to phone for an ambulance, only having stomach ache. An ambulance can be very expensive. Visiting a doctor is entirely sufficient.
- A driving license is required to drive a car. Maybe you have to apply for an international driving license. Driving without a license is punished with up to one year in prison.
- You should be aware that you have to do your errands from Monday to Saturday. All shops are closed Sundays. Authorities and banks are only open Mon-Fri.
- It's possible to pay with credit card in some shops; however, it's not accepted everywhere, so keeping cash with you is recommended.
- Always check your emails, as otherwise you will miss important information and fail to meet deadlines.
- Health insurance is required for living in Germany and don't forget to pay the fees!
- Nobody jaywalks! No one. Don't try to beat the red light. The little green man on the traffic lights will let you know when it is safe to cross the road.
- Germans take their recycling seriously! Expect to have at least 4 bins in your house and learn how to separate your trash correctly. When it's time for collection, put the bins out on the sidewalk and the refuse collection will pick it up.
- Don't forget to bring your own bag, basket or backpack whenever you shop or else you'll end up paying for each plastic bag you need for your purchases.
- Germans are one of the most punctual people, so they take it very seriously to be ready on time. Take care of that and try to be punctual, too. Otherwise, you will be considered an impolite person.

## ▶ Map Deggendorf

### Index of DIT Buildings:

- A - Faculty Business Administration & Business Informatics (Computer Science)
- B - Administration/Main Auditorium, International Office, Career Service, Language Centre
- C - Faculty Mechanical Engineering & Mechatronics, Copyshop
- D - Faculty Civil & Construction Engineering
- E - Faculty Electrical Engineering & Media Technology + faculty Applied Natural Sciences & Industrial Engineering
- F - Cafeteria
- G - Library, Data Centre, IT-Support
- H - staff administration offices
- I - Lecture theatres
- J - Media Technology
- K - Business Informatics
- L - Mechanical Engineering, faculty Applied Natural Sciences & Industrial Engineering
- ITC2 - Innovation and technology campus, lecture rooms, staff administration offices

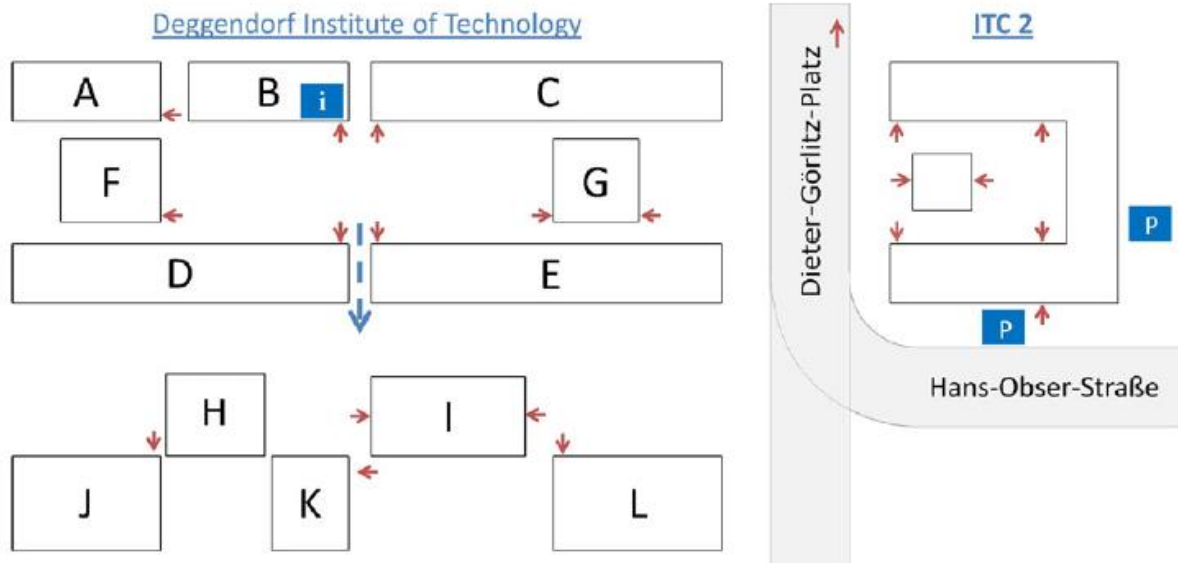

Example: Room A 214

The letter means the building (here: building A), the first number means the floor (here second floor) and the last numbers mean the room (here room 14). There are signs at every room. The rooms at ITC 2 are named e.g. sem (1), this means Seminarraum 1.

## **Important semester dates**

### **WINTER SEMESTER**

October 1st - March 14th

Approx. 14 weeks of classes: end of classes = end of January

Approx. 3 weeks of exams: end of January - mid February

Semester break: mid February - mid March

Christmas break: December 24th - January 6th

### **SUMMER SEMESTER**

March 15th - September 30th

Approx. 15 weeks of classes: end of classes = mid July

Approx. 3 weeks of exams: end of June - mid July

Semester break: beginning of August - end of September

Easter Holidays: vary each year

Whitsun Holidays: vary each year

### **Holidays:**

New Year's Day: January 1st

Easter: Holy Thursday, Good Friday and Easter Monday

Labour Day: May 1st

Whitmonday: usually end of May, beginning of June

National Day: October 3rd

Christmas: December 25th and 26th

## **Important telephone numbers**

**HOSPITAL** Deggendorf: +49 (0)991 380-0

**AMBULANCE** Emergency: 112

**POLICE** Emergency: 110; Police station Deggendorf: +49 (0)991-3896-0

**FIRE SERVICE** Emergency: 112

## **Contact and advice**

### **International Office**

Technische Hochschule Deggendorf

Dieter-Görlitz-Platz 1

94469 Deggendorf

Tel: +49 (0)991 3615-242/ -209

welcome@th-deg.de

### **Course Assistant**

Johanna Aschenbrenner  
Land-Au 27  
94469 Deggendorf  
+49 (0)991 3615-423  
johanna.aschenbrenner@th-deg.de  
Room 2.12

## **Library**

It's located at the main campus. You need a guided introduction to use all the functions of the library. We will organize an appointment in november for all of you together.

## **Centre for studies**

They advise you on all matters relating the application process and admissions as well as give you academic advice during your studies about aspects concerning examination regulations and the completion of internships. Your personal information is kept on register there so please inform them of all changes (especially name and address changes) in sufficient time.

It's located in Block B at the ground floor. Your contact person is

Johanna Maurer  
+49 (0)991 3615-454  
johanna.maurer@th-deg.de  
Room B 006

## **Career Service**

In addition to individual career and application coaching, they provide an online job board with postings specifically geared towards DIT students.

Every semester, the Career Service offers a wide variety of seminars which help students to build important skills for their studies and their future career and also support students in their personal development. Furthermore they'd like to provide interested students with information and guidance about scholarships and our institute's own mentoring programmes.

Your contact person is

Claudia Probst  
+49 (0)991 3615-223  
claudia.probst@th-deg.de  
Room B 218

## **International Office**

The International Office is the central facility for all international students at the DIT. It supports you in all matters before and after your arrival as well as during your stay in Deggendorf. It helps you with questions concerning your studies and gives you information regarding accommodation, financing, visas as well as further counselling and other services. You can find them in Room B 210.

## **Language and electives centre**

Moving confidently and appropriately in a linguistically active manner in daily study and professional environments is a necessary cross-occupational key skill which is indispensable both for future working life and for preparation for a study or internship abroad. The Language and Electives Centre meets the challenges of today's globalised world with the following services:

- Language courses (during the semester as well as intensive language courses during semester breaks), placement tests and certificates
- Electives
- Guidance and mentoring for the Tandem Programme
- Every year language trips
- and much else

You can find them in Room B 205

## **Copy Shop**

We have a Copy Shop directly located at the Campus in Room C 012. It's opened from 09.00 am to 04:00 pm.

## **Campus Canteen and Café**

The Student Union campus canteen (on the 1st floor) offers the following at lunchtime:

- Two main dishes
- One vegetarian meal
- Various side dishes
- Starters and desserts

You can buy snacks and small dishes at the Café at the ground floor.

For payment you need your student ID chip card.

## **Sports**

University sports are open to all students and staff, focusing on popular recreational sports for relaxation after a busy day of studying and research. Competitive participants have the opportunity to compete at university championships in one of our teams or as an individual. Sporting activities are held at locations provided by external organizations and clubs.

When participating in university sports, a valid student card or ID card must always be carried, which is to be shown on request. Participants' identification will be checked. In the case of unauthorized participation, employees and course instructors are entitled to refer persons to the sports facility.

For further information check our website.

## **Student ID**

The card will be given to you at the personal registration. It's used as student identification and also as a method of payment in various campus service areas.

The expiry date of the student ID card must be printed on the card to warrant its validity. This is needed to obtain various student discounts, but is irrelevant for usage in DIT. Don't remove any obsolete by hand as you might damage the card. Our validity terminal is in the foyer of block B, in front of room B 006. Please follow instructions on the screen.

## First steps in the IT

### 1. User name

- User name consists of:
  - 1st letter of first name (lowercase letter)
  - 1st letter of family name (lowercase letter)
  - day of birth (2 digits)
  - last 3 figures of the matriculation no.
- Example:  
Hans Muster (Matr. no. 00123456), born 05.12.1975 → hm05456

### 2. Password

- The standard password consists of:
  - 1st letter of first name (lowercase letter)
  - Matr. no. (without leading zeros)
  - hyphen (-)
  - 1st letter of family name (lowercase letter)
  - year of birth (4 digits)
- Example: Hans Muster (Matr. no. 00123456), born 1975 → h123456-m1975
- Please note: Your matriculation number can be found on your admission certificate and is different to your application number.

#### **Changing your password:**

To change your password please see: <https://idm.th-deg.de>  
(access only on campus or via VPN)

### 2. After registration

- Important drive letters:
  - I: your own home drive (5 GB)
  - V: central drive (hub)

### 3. Email address

- Your email address:  
[firstname.lastname@stud.th-deg.de](mailto:firstname.lastname@stud.th-deg.de)
- Note: In case of similar names, the e-mail address will be extended by a consecutive number:  
[firstname.lastname2@stud.th-deg.de](mailto:firstname.lastname2@stud.th-deg.de)
- Your e-mail password: see point 2
- Visit <https://idm.th-deg.de> (access only on campus or via VPN) if unclear what your e-mail address looks like

### 4. Public Distribution Lists



- To receive further information by e-mail (News, events, etc.), you can subscribe to the according public distribution lists at <https://idm.th-deg.de> in the menu item „Public distribution lists“

## 5. Important Internet addresses

- The University website:  
<https://www.th-deg.de>
  - Access to the e-mail system:  
<https://webmail.th-deg.de>
- Intranet:  
<https://intranet.th-deg.de/en>
- E-Learning  
<https://ilearn.th-deg.de>
  - Cloud-Storage  
<https://nextcloud.th-deg.de>

## 6. Certificate of Enrollment

- Open the Primuss-portal in your browser:  
<https://www.primuss.de/portal-thd> (Login with your user name; see point 1)
  - Click on „My Study“.
  - Click on „Continue with Notifications“.
  - Select the required form of enrolment certificate.
- A PDF-file will be created which can be printed or saved and sent by email.

## 7. Access to Network

- WLAN „eduroam“, for details see Intranet:  
<https://intranet.th-deg.de/en/rz/wlan/eduroam>
- WLAN „@BayernWlan“
- VPN access via the WLAN „campus-vpn“ or externally, for details see Intranet:  
<https://intranet.th-deg.de/en/rz/vpn>

## 8. Offers

- Microsoft Azure Dev Tools for Teaching (e.g. Windows 10)
- Microsoft Office 365 ProPlus
- Sophos Antivirus
- campusAuction (auction system)
- Pinboard (small advertisements)
- Survey systems (LimeSurvey, THDoodle)

For any further information, please visit our homepage [www.th-deg.de/en/](http://www.th-deg.de/en/). It's well structured and contains even more information about everything you need.